

**SAILOR SART II****9GHz Search  
And Rescue  
Transponder**

All products from SAILOR are designed for the rough conditions at sea and the SAILOR SART II is no exception. The SAILOR SART II is small and easy to use, offering safety in critical situations.

The SAILOR SART II is a 9 GHz X-band Radar transceiver and has been designed for assisting rescue operations in accordance with IMO, GMDSS requirements.

When a radar signal is received from a vessel or aircraft, the SAILOR SART II automatically transmits a response signal, which clearly identifies the

survival craft on the radar screen by means of a stream of 12 in-line dots. Once activated, the SAILOR SART II will remain in standby mode for over 96 hours.

- Ship or survival craft options
- Waterproof to 10 m
- Maintenance free
- Replaceable, 5 year battery pack
- Audio/visual indication of operation
- Built-in test facility
- Integral lanyard
- Mounting options – internal/external

## TECHNICAL DATA

### CONFIGURATION:

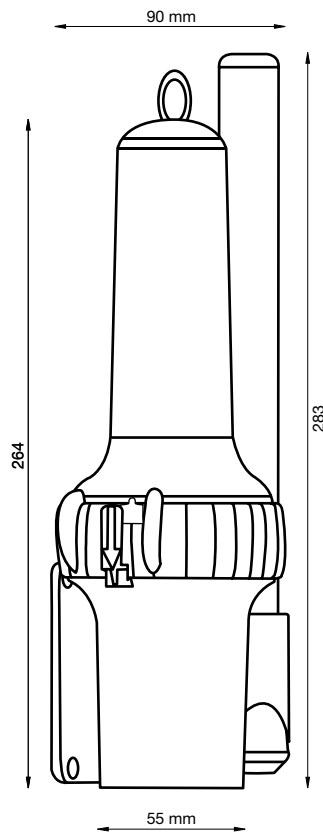

External mounting

Internal mounting

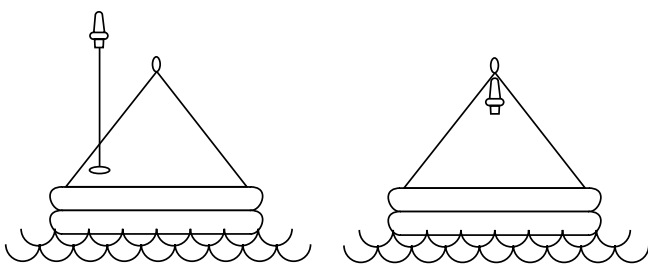

### GENERAL SPECIFICATIONS:

Receiver Response:	9.2-9.5GHz, sensitivity better than -50dBm
Transmitter Response:	12 forward and return sweeps through the range 9.2-9.5GHz. Nominal sweep times 7.5µs forward and 0.4µs return. Minimum recovery time following excitation, less than 10µs. Response reply to receiver signal less than 0.5µs.
Radiated Power (ERP):	Not less than 400mW (+26dBm)
Duration of Operation:	96 hours in standby condition followed by a minimum 8 hours of transmission while being continually interrogated with a pulse repetition frequency of 1kHz.
Temperature Range:	-20°C to +55°C operational -30°C to +65°C storage
Antenna Characteristics:	Vertical beamwidth at least +/- 12.5 degree relative to the horizontal plane of the radar transponder. Azimuthal beamwidth omni-directional to +/- 2dB.
Effective Antenna Height:	1 metre or greater.
Weight:	530g (with mast and bracket)
Dimensions:	264 mm long x 90 mm diameter Depth with bracket 101 mm.

Specifications subject to change without prior notice.

To comply with UN regulations for transportation, as of January 2003 any products containing lithium batteries will be classified as UN Hazardous Class 9.

SAILOR products cover the need for communication on board all types of vessels - from leisure and fishing to SOLAS. The wide range of maritime communications products covers everything from VHF and MF/HF radios to state-of-the-art satellite systems as well as AIS, SSAS and complete GMDSS solutions.